

# 684-52 OEM Proximity Reader

## Data Sheet

### Overview

The 684-52 OEM proximity reader consists of three parts: a potted unit containing the electronics, a front cover, and an optional spacer plate. A fixed 10 way colour-coded cable protrudes from the back of the potted unit.

The reader will read the code from an RFID transponder and output the code in one of many user selectable formats.

The unit also allows for user control of the three LEDs and sounder. A 6-way DIP switch under the front cover is used to select the required output format and LED operational modes.



### Specifications

- Power requirements: 5.0-13.6V dc. Current consumption is 100 mA typical (80mA at 5V).
- RF Frequency: 125 kHz.
- 40 bit read only transponders supported: EM4001 family, TEMIC e5550 and equivalent devices.
- Output formats supported: Wiegand (42-bit, 34-bit, and 26-bit), Mag Stripe emulation, Clock/Data, RS232 (9600,n,8,1) EIA and TTL levels.
- Continuous (while tag in the field) or single transmission.
- Typical reading range with supply voltage in range 5.5V-13.6V: keyring tag with 20mm coil - 85mm, ISO card with 50mm coil - 175mm.
- Typical reading range with supply voltage at 5.0V: keyring tag with 20mm coil - 80mm, ISO card with 50mm coil - 160mm.
- 3 LEDs (GREEN, RED, YELLOW).
- Sounder emits a 60ms beep at 4 kHz when a transponder is read. In addition sounder operates while SOUND input is pulled low.
- Operating temperature range: -20°C - +60°C.
- 10 way cable: 1m long
- Weight: 90 grams.
- Dimensions: reader 89 x 45 x 16 mm, optional spacer plate 89 x 45 x 7 mm

## Physical Dimensions and Mounting Details

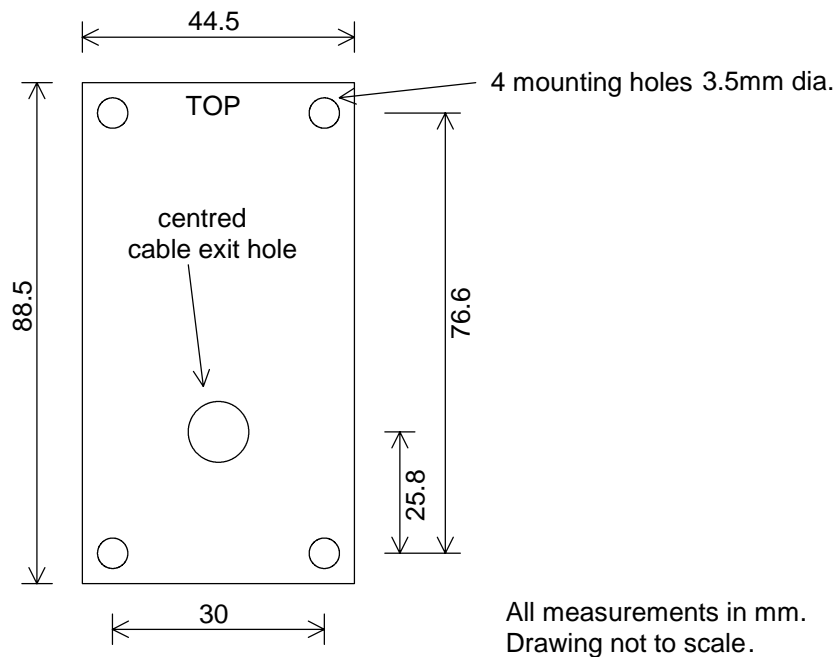

If the spacer plate is used the reader cable may be brought out of one of four exit points on the spacer: top, bottom, left or right. This enables the cable to be run on the surface of the wall. If no spacer plate is used a minimum hole size of 6.5mm must be drilled in the wall at the cable exit position as shown above to allow the cable to exit perpendicular to the reader.

The optional spacer plate may also be used when mounting the reader on a metal surface to reduce the negative effects of metal on the read range.

## Connections

The table below details the function of each wire:

Colour	Name	Function
GREY	PRESENT	Pulses low when an RFID tag is detected. It stays low while the module output is active.
WHITE	CLOCK/DATA0/TX	Outputs RFID tag code in selected format.
BROWN	DATA/DATA1	Outputs RFID tag code in selected format.
YELLOW	YEL-LED	Controls Yellow LED in LED Mode 1.
ORANGE	RED-LED	Controls Red LED in LED Mode 1.
GREEN	GRN-LED	Controls Green LED in LED Mode 1 and both Red and Green LEDs in LED Mode 2.
BLUE	SOUND	Controls Sounder
PURPLE	RS-232	RS-232 output
RED	+VDC	Connect +5V - +13.6V from power supply.
BLACK	0V	Connect 0V from power supply.

Note: LED and SOUND inputs are active low. The input is internally pulled high and may be pulled low by an open collector transistor or driven low by the output of a 5V CMOS or TTL gate.

## Output Mode Selection

The 6-way switch is used to select the output format and LED mode. The required setting is selected from the following tables:

### Output Format Table

SW 1	SW 2	SW 3	SW 4	Output Format
ON	ON	ON	ON	Inhibit - turn off coil
ON	ON	ON	OFF	RS232 - 24 bit
ON	ON	OFF	ON	RS232 - 32 bit
ON	ON	OFF	OFF	RS232 - 40 bit
ON	OFF	ON	ON	Unused
ON	OFF	ON	OFF	Unused
ON	OFF	OFF	ON	Unused
ON	OFF	OFF	OFF	Unused
OFF	ON	ON	ON	Fast Mag Stripe - 40 bit
OFF	ON	ON	OFF	Mag Stripe - 24 bit
OFF	ON	OFF	ON	Mag Stripe - 32 bit
OFF	ON	OFF	OFF	Mag Stripe - 40 bit
OFF	OFF	ON	ON	Basic Clock/Data
OFF	OFF	ON	OFF	Wiegand - 26 bit
OFF	OFF	OFF	ON	Wiegand - 34 bit
OFF	OFF	OFF	OFF	Wiegand - 42 bit

### LED Mode Table

Mode #	SW 5	LED Mode
1	ON	3 Individual LEDs each controlled by their own input
2	OFF	RED/GREEN with single control line (GRN-LED)

#### Note

1. In LED Mode 2, both RED and GREEN leds are controlled by the GRN-LED input. When the GRN-LED input is floating or pulled high, the RED led is on and the GREEN led is off. When the GRN-LED input is pulled low (connected to 0V) the GREEN led is on and the RED led is off. The YELLOW led is always off.

### Continuous/Single Transmission Mode Table

Mode	SW 6	Operation
Continuous	ON	While a tag is in the reader's field the reader will continuously transmit the code in the format chosen by DIP switches 1-4. The repetition period is dependent on the format chosen but varies between 65ms and 230ms.
Single	OFF	Single transmission when tag is brought into the field. Tag must be removed from field for at least 1 second before a read of this tag is possible again.

## Power Connections

The reader has an internal low dropout 5V regulator and so for maximum performance the input voltage must be smooth DC between 5.5V and 13.6V. The reading distance is unchanged for input voltages between 5.5V and 13.6V. For input voltages below 5.5V the read range drops off slightly as given in the specifications earlier. If 5V is supplied to the reader this should be noise-free to achieve maximum possible read ranges.

## RS232 Output modes

There are two RS232 outputs from the reader. The RS-232 wire (purple) outputs EIA voltage levels: -5V for a binary '1' state and +5V for a binary '0' state. This output is suitable to connect directly to the serial COM port of a PC. The TX wire (white) outputs TTL levels: +5V for a binary '1' state and 0V for a binary '0' state. This output is suitable to connect directly to the USART of a microprocessor. RS232 format data is outputted from both wires when the RS232 modes are selected.

The baud rate is 9600. Data format is 8 bits, no parity, and 1 stop bit.

The tag code is output in the following structure:

STX (02h)	DATA (ASCII)	CR (0Dh)	LF (0Ah)	ETX (03h)
-----------	--------------	----------	----------	-----------

The DATA bytes vary according to the number of bits being output:

### 40 bit mode

DATA = 10 ASCII characters representing the 40 bit hexadecimal code of the tag e.g. '0410B2F12A' (30 34 31 30 42 32 46 31 32 41 hex)

### 32 bit mode

DATA = 10 ASCII characters representing the least significant 32 bits of the tag converted to a decimal number e.g. '0280162602' (30 32 38 30 31 36 32 36 30 32 hex)

### 24 bit mode

DATA = 8 ASCII characters representing the least significant 24 bits of the tag converted to a decimal number e.g. '11727146' (31 31 37 32 37 31 34 36 hex)

## Clock/Data Mode

In this mode all 40 bits of the tag are clocked out with an eight bit header and an eight bit checksum.

Header (11111110)	Data (40 bits)	Checksum
-------------------	----------------	----------

The header is hex FE. The data consists of all 40 tag bits sent MSB first. The checksum is a byte addition of the 5 bytes of tag data e.g tag 0410B2F12A has a checksum of 04+10+B2+F1+2A=E1.

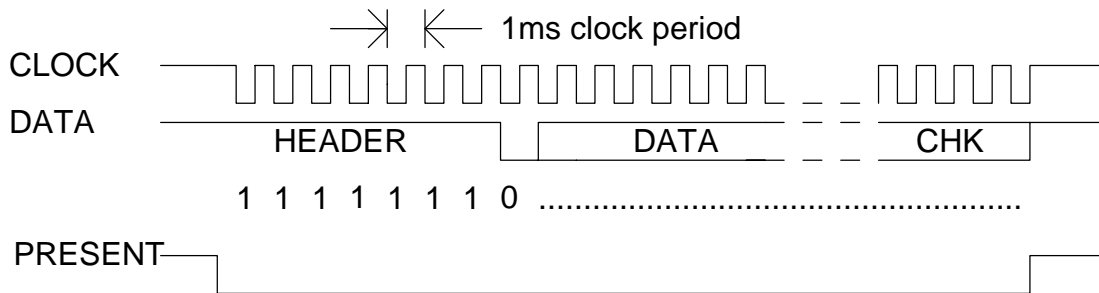

Data is set up on the falling edge of the clock and is stable on the rising edge of the clock.

## Wiegand Output Modes

In this mode the tag code is pulsed out on DATA0 (white wire) and DATA1 (brown wire). Both are normally high. When a tag is presented to the reader 26/34/42 bits are transmitted in the following way:

A binary 1 is represented by a 100 us pulse low on DATA1. A binary 0 is represented by a 100 us pulse low on DATA0. There is a 2 ms inter bit delay.

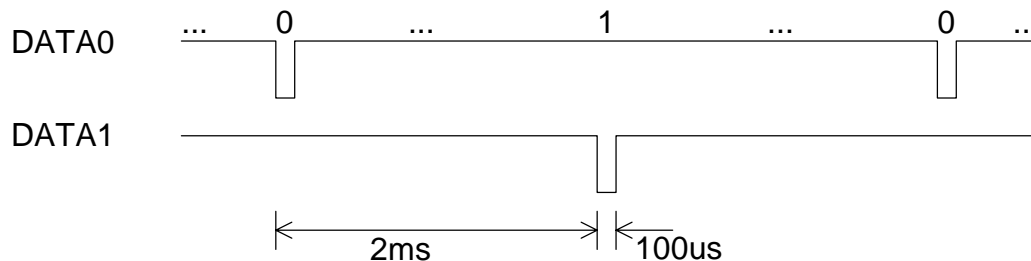

### 42 bit mode

42 pulses are transmitted:

- The first bit is the even parity of tag bits 1-20.
- All 40 bits of the tag code (MSB first).
- The last bit is the odd parity of tag bits 21-40.

### 34 bit mode

34 pulses are transmitted:

- The first bit is the even parity of tag bits 9-24.
- The least significant 32 bits of the tag code (MSB first).
- The last bit is the odd parity of tag bits 25-40.

### 26 bit mode

26 pulses are transmitted:

- The first bit is the even parity of tag bits 17-28.
- The least significant 24 bits of the tag code (MSB first).
- The last bit is the odd parity of tag bits 29-40.

## Mag Stripe Modes

In this mode the decimal tag number is clocked out on CLOCK (white wire) and DATA (brown wire) at 100 characters per second. The format is standard as found on Track 2 of a magnetic card:

10 leading 0's	SS	DATA	ES	LRC	5 trailing 0's
----------------	----	------	----	-----	----------------

SS = start sentinel (B hex).

ES = end sentinel (F hex).

LRC = longitudinal redundancy check.

DATA varies according to the number of bits selected:

### 40 bit mode

DATA = 13 decimal digits with leading zeros. The most significant decimal digit is transmitted first.

### 32 bit mode

DATA = 10 decimal digits with leading zeros. The most significant decimal digit is transmitted first.

### 24 bit mode

DATA = 8 decimal digits with leading zeros. The most significant decimal digit is transmitted first.

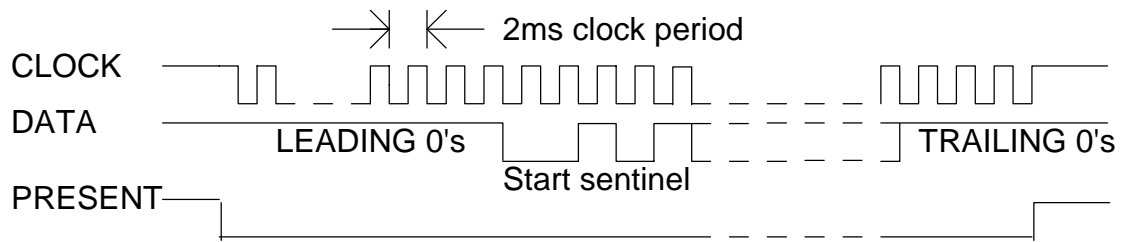

Each character is 5 bits long. The first four bits are the hex digit (0-F) least significant bit first. The fifth bit is an odd parity bit. A 0 is represented by a high level on the DATA wire and a 1 is represented by a low level on the DATA wire. Data is set up on the falling edge of the clock and is stable on the rising edge of the clock. The PRESENT output goes low for the duration of the transmission simulating the CARD PRESENT from a mag card reader.

### Fast 40 bit mode

This mode differs from the standard 40bit magstripe mode in the following ways:

- DATA=14 decimal digits with leading zeros.
- The clock period is 200us.
- 10 trailing 0's

All other aspects of this format are the same as the other magstripe formats.